

Fuelling products

Hydrant shutoff valve

F352 and F353

F353 hydrant shutoff valve shown right is a representative of the unit covered by this catalog page



F352 Hydrant shutoff valve

The Meggitt F352 hydrant shutoff valve is a lanyard operated 6-inch by 4-inch shutoff valve designed, tested, and found to fully comply with the requirements of the IP standard for aviation hydrant pit systems "Recommended Arrangements for New Facilities" dated April 1980. The Meggitt F353 hydrant shutoff valve is similar to the F352 except it has a 4 inch ASA inlet flange and is nearly 4-inches shorter.

The F352/F353 hydrants are provided with both an automatic and a manual means of closing off the main chamber to allow removal and maintenance of the servo assembly and strainer while the main valve is still under pressure.

See note below.

Ordering data

The basic F352 and F353 hydrant valves are lanyard operated shutoff valves with API, 4-inch outlets. Inlets mate 6 and 4-inch ANSI flanges respectively. The F352 includes a four mesh stoneguard as standard equipment. Both units are available with various modifications.

Note! Under hydrant should always be turned off prior to any maintenance.

Key Features

- Fully complies to third edition of the API/IP 1584 requirements
- ANSI 150 lb. rated flange mates 6-inch ANSI 300 lbs. flange (F352)
- Portions of valve are maintainable in PIT with valve under pressure
- Air deadman pilot control available
- Four mesh stone guard standard
- 20 mesh internal strainer optional
- 4-inch API outlet
- Six position product selection
- Fits in 18-inch diameter pit
- Available with dual pilot shutoff as a modification
- Unit meets NFPA 407 requirements

Meggitt Control Systems

Our product competencies & services:
Aerospace valves | Thermal management solutions | Environmental control systems | Electro-mechanical products
Ground fuelling products | Energy products | Aftermarket services

MEGGITT
smart engineering for
extreme environments

Fuelling products

Hydrant shutoff valve

F352 and F353

Key Dimensions

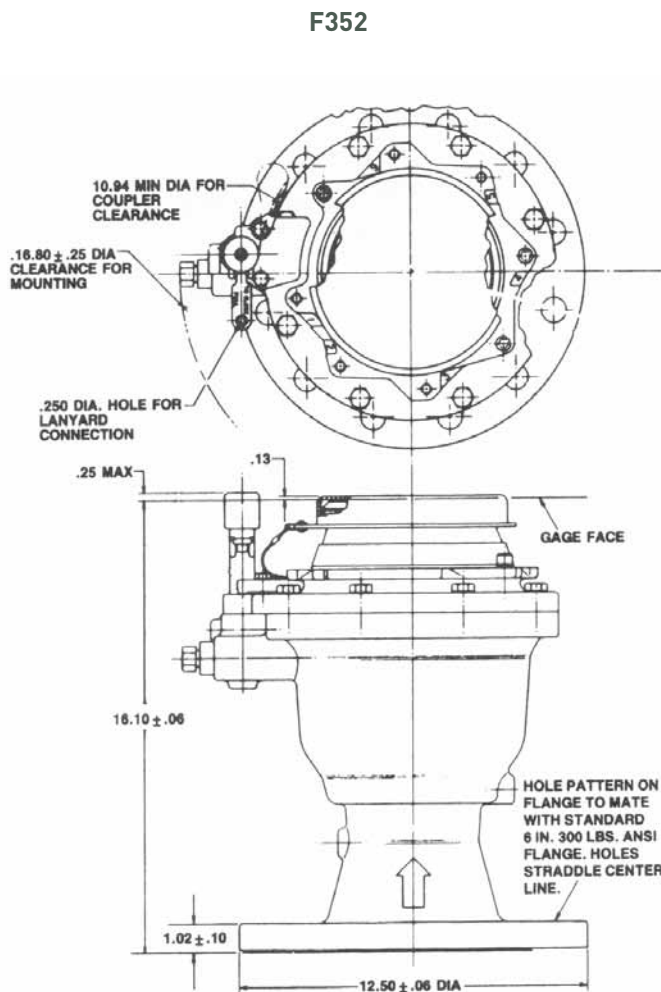

Operating characteristics

- Max. operating pressure - 275 PSI (18.7 BAR)
- Opening time - 5 to 10 seconds
- Closing time - adjustable from two to five seconds (factory set at five seconds)
- Pressure drop - F352 - 14.5 PSI (1.00 BAR) at 4500 1/min. (1189USGM)
- Weight - F352 - 40Kg (88 lbs)
- Peak surge pressure - F352 - 305 PSI (21 BAR)

Meggitt Control Systems

Our product competencies & services:
Aerospace valves | Thermal management solutions | Environmental control systems | Electro-mechanical products
Ground fuelling products | Energy products | Aftermarket services

MEGGITT
smart engineering for
extreme environments

Fuelling products

Hydrant shutoff valve

F352 and F353

Key Dimensions

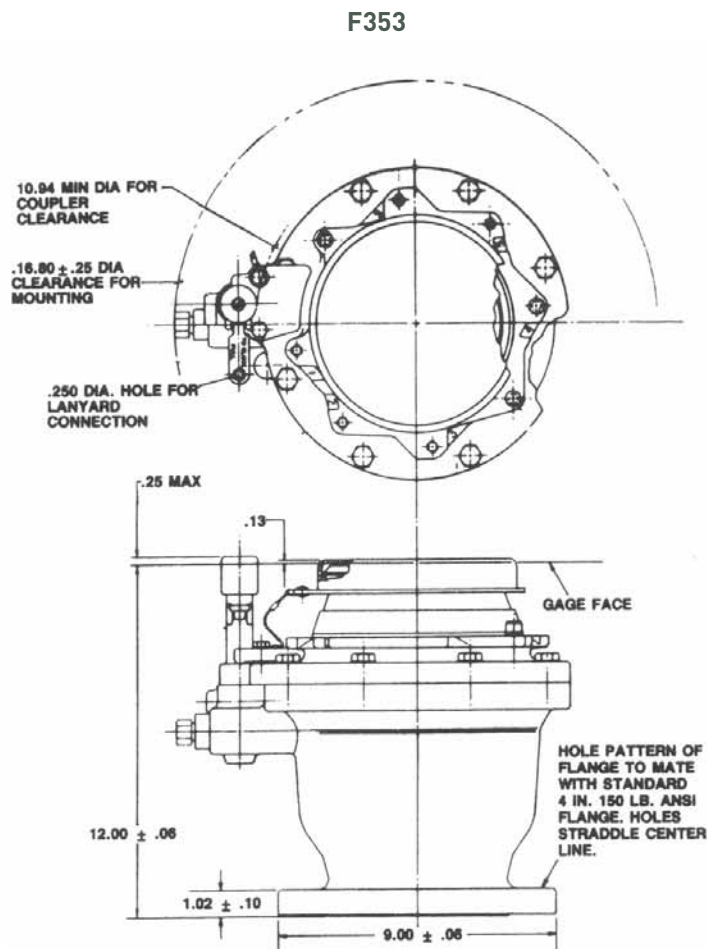

Operating characteristics

- Max. operating pressure - 275 PSI (18.7 BAR)
- Opening time - 5 to 10 seconds
- Closing time - adjustable from two to five seconds (factory set at five seconds)
- Pressure drop -
F352 - 14.5 PSI (1.00 BAR) at 4500 1/min. (1189 USGM)
F353 - 12 PSI (0.83 BAR) at 4500 1/min (1189 USGPM)
- Weight - F353 - 27.51(g (60 lbs)
- Peak surge pressure - F353 - 305 PSI (21 BAR)

Meggitt Control Systems

Our product competencies & services:
Aerospace valves | Thermal management solutions | Environmental control systems | Electro-mechanical products
Ground fuelling products | Energy products | Aftermarket services

MEGGITT
smart engineering for
extreme environments

Fuelling products

Hydrant shutoff valve

F352 and F353

Key Dimensions

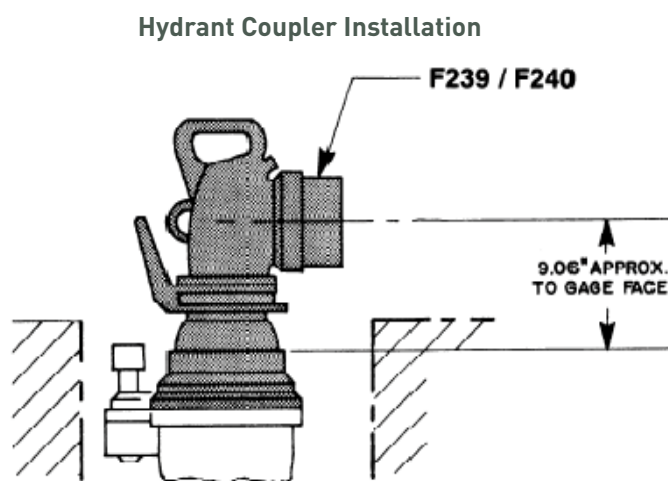

Mating components

Both the F352 and F353 are designed to be used with API hydrant couplers.

The Meggitt couplers conforming to this requirement are as follows:

- F239 Hydrant coupler with deadman control and/or pressurecontrol
- F240 or F250 Hydrant coupler

Note! Opening and closing time may vary slightly with inlet pressure.

Contact

Meggitt North Hollywood

12838 Saticoy Street
North Hollywood
California 91605-3505
USA

Tel: (818) 765-8160
Fax: (818) 759-2194

www.meggitt.com

Meggitt Control Systems

Our product competencies & services:
Aerospace valves | Thermal management solutions | Environmental control systems | Electro-mechanical products
Ground fuelling products | Energy products | Aftermarket services

MEGGITT
smart engineering for
extreme environments